

X-ECO 2415

Single INVERTER

COOLING



HEATING

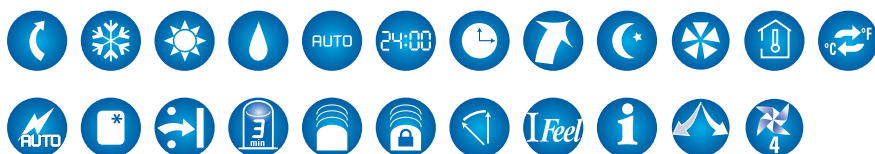

Code		07010345
Model		XECO-2415
Size	kBtu/h	24
P Design in Cooling (1)	kW	6,5
Energetic Efficiency Class in Cooling		A++
SEER		6,1
Annual electric consumption in Cooling	kWh/y	373
Climatic design area in Heating		Warmer / Average / Colder
P Design in Heating (2)	kW	5,8 / 5,8 / 5,8
Energetic Efficiency Class in Heating		A++ / A+ / A
SCOP		5,0 / 4,0 / 3,4
Annual electric consumption in Heating	kWh/y	1624 / 2030 / 3582
Cooling capacity (3) nom (min-max)	kW	6,50 (2,53 - 7,00)
Cooling Absorbed power (3) nom (min-max)	kW	2,01 (0,60 - 2,35)
Heating capacity (4) nom (min-max)	kW	7,00 (2,53 - 7,60)
Heating absorbed power (4) nom (min-max)	kW	1,89 (0,60 - 2,50)
Supply voltage	V/ph/Hz	230/1/50
Maximum current absorbed	A	12,5
Refrigerant load R410A (GWP = 2088) / CO ₂ eq.	kg / t	1,8 / 3,76
Max. distance between I.U. and E.U.	m	25
Max. height between I.U. and E.U.	m	10
Refrigerant piping (Liquid)	Ø mm (inch)	6,35 (1/4")
Refrigerant piping (Gas)	Ø mm (inch)	15,9 (5/8")
Model Outdoor unit		XECO-2415E
Cooling operating field	°C	-15÷43
Heating operating field	°C	-20÷24
Air flow	m ³ /h	3200
Sound power level	dB(A)	68
Sound pressure level (5)	dB(A)	46
Compressor type		Rotary
IP grade of protection		IP24
Outdoor unit dimensions	LxHxDxE mm	980x790x427x610x395
Outdoor unit weight	kg	56
Model Indoor Unit		XECO-2415W
Cooling capacity (1) nom (min-max)	kW	6,45
Dehumidification (1)	L/h	2,0
Heating capacity (3) nom (min-max)	kW	7,00
Maximum power absorbed	W	40
Maximum current absorbed	A	0,31
Air flow (max-min)	m ³ /h	1000-800-700-550
Sound power level (max-min)	dB(A)	63-57-53-46
Sound pressure level (max-min) (6)	dB(A)	46-40-36-29
IP grade of protection		IP20
Indoor unit dimensions	LxHxD mm	1007x315x226
Indoor unit weight	kg	14

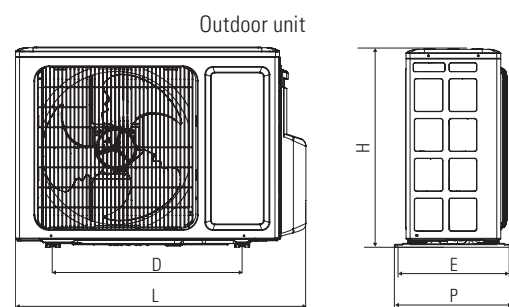
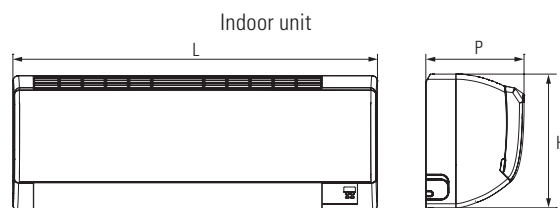

- (1) Cooling P design: internal temperature = 27(19) °C; external temperature = 35 °C.
- (2) Heating P design: internal temperature = 20 °C; external temperature = 2 °C / -10 °C / -22 °C.
- (3) Cooling standard nominal conditions: internal temperature = 27(19) °C; external temperature = 35 °C.
- (4) Heating standard nominal conditions: internal temperature = 20 °C; external temperature = 7 °C.
- (5) Sound pressure level measured (in open space) at a distance of 5 m from the unit and with directional factor equal to 2.
- (6) Sound pressure level measured (in closed space) at a distance of 3 m from the unit and with directional factor equal to 2 and with constant room equal to 300 m³.



Ventilation

Three speeds available plus automatic.



Cooling



Heating



DRY Dehumidification

To reduce relative humidity without turning the temperature down too much.



AUTO Automatic operation

This selects the operating mode based on pre-set parameters to provide the room with conditions of utmost comfort.



Digital clock

Visualization of the clock from the remote control.



TIMER Timer setting

To preset the startup and the shutdown of the air conditioner.



Anti-dust filter

The indoor unit is equipped with a purification filter of the dust.



Compressor maintenance

To ensure a longer compressor lifetime, we have equipped the compressor with a start and stop controller. Waiting time between stop and start is three minutes



Remote control

Liquid crystal display (LCD) with clear indication of functions.



Remote control functions block

To block all the functions directly from the remote control.



AIRSWING

Automatic movement of the vertical flap

Automatic adjustment of the vertical air flow direction.



I Feel function

The real perceived room temperature from the remote control is sent to the infrareds receiver of the internal unit which will set it automatically.



Wire remote control

Standard connection with cable length mt 8.



SLEEP Night-time setting

To maintain optimum temperature during sleep periods.



Turbo function

To cool or heat the room intensely.



Blow function

Fan runs when unit is stopped to prevent generation of mould and odors inside indoor unit.



TEMP function

When the TEMP symbol is displayed the internal temperature of the room is showed for 5 seconds.



Double temperature range

It allows to set/visualize the temperature in °C or °F.



AUTORESTART Automatic restarting

To automatically restart the system after an interruption of the power supply.



AUTODIAGNOSIS Maintenance

It indicates any functioning problems.



Wire remote control functions block

To block all the functions directly from the wire remote control.



Water drainage pump

Water upwards drainage mechanism creates the ideal solution to assure a perfect water drainage, it offers more flexibility to the installation.



Ventilation Four delivery openings

The internal unit has four air delivery openings. The air flow direction is adjusted by four baffles.



Dual flow

The unit foresees 2 options for the air flow management. Upper mode or upper + lower mode.



Ionizer

Air conditioners are equipped as standard with Cold Plasma system which assures an air sterilization above the 95% together with the smell eliminationnegative ions.



Manual movement of horizontal deflector

To manually adjust air flux horizontally.



Multi-speed fan

Other speed settings are available (the number within the symbol indicates the quantity).

